

# TORQUEMASTER

## BRUSH SERVO MOTORS



## **2100** SERIES

### Performance Benefits

Torque Systems specializes in the design of high performance brush servo motors that provide efficiency, flexibility of application, and a long and trouble-free service life. Our TORQUEMASTER® 2100 series is no exception.

With fast response, accurate control and high torque-to-inertia ratios, you can count on the TORQUEMASTER 2100 Series of brush servo motors to provide smooth operation throughout a full speed range. The 2100 Series delivers smooth and superior low speed performance, and maximum power ratings with low thermal resistance for high speed performance. In addition, with maximum torque in a smaller package, you can count on better pricing for a better overall value.

When integrated with high performance brush amplifiers, TORQUEMASTER 2100 Series brush servo motors provide effective and highly efficient motion control solutions for a wide range of applications—including factory automation, packaging, robotics, machine tools, medical instrumentation and more.

### Design Features

TORQUEMASTER 2100 Series brush servo motors are rated from 12 oz.-in. to 53 oz.-in. with speeds and torque stability up to 6500 RPM. They utilize the latest in high performance permanent magnet technology, and are available in eight standard windings (as well as custom windings) to meet your most demanding applications.

Each brush servo motor in the TORQUEMASTER 2100 Series is ruggedly designed and manufactured for reliable performance.

Motors can be customized to fit your exact application with tachometers, encoders, brakes and other options.

**Series 2100, is a high performance, permanent magnet brush servo motor for use in various industrial direct drive or geared servo systems**

- Rugged industrial construction
- Continuous torque ratings up to 53 oz.-in. — with speeds up to 6500 RPM (no load)
- Peak torque ratings up to 300 oz.-in.
- High torque-to-inertia ratio delivers maximum torque per frame size
- Superior low speed performance
- Numerous custom options available



Sold & Serviced By:



Toll Free Phone (877) SERV098  
Toll Free Fax (877) SERV099  
[www.electromate.com](http://www.electromate.com)  
[sales@electromate.com](mailto:sales@electromate.com)

# BRUSH SERVO MOTOR CHARACTERISTICS

SYMBOL			UNITS	2105	2110	2115	2120	2130
T <sub>C</sub>	Cont. Torque	Oz-In		12	18	30	38	53
T <sub>P</sub>	Peak Torque	Oz-In		50	100	150	200	300
T <sub>F</sub>	Static Friction	Oz-In		3	3	3	3	3
F <sub>I</sub>	Viscous Friction	Oz-In/KRPM		0.2	0.3	0.3	0.4	0.5
T <sub>R</sub>	Cogging Torque	Oz-In		0.2	0.3	0.5	0.5	0.5
J <sub>M</sub>	Inertia	Oz-In-sec <sup>2</sup>		0.0018	0.0031	0.0044	0.0057	0.0083
R <sub>TH</sub>	Thermal Res	Deg C/watt		6.9	6.2	5	4.5	3.8
T <sub>TH</sub>	Thermal Time	Minute		10	10	15	15	20
t <sub>m</sub>	Mech Time	Millisec		24.3	12.19	8.62	8.07	7.20
t <sub>e</sub>	Elect Time	Millisec		1.6	1.9	2.1	2.1	2.2
F <sub>C</sub>	Commutation	Watts x Oz In / Amps		488	722	1260	1548	2116
Wt	Weight	Lbs		1.9	2.9	3.1	3.3	4.3

Note: All values at 25°C Ambient.

## WINDING

<b>A</b>	K <sub>T</sub>	Torq. Sens.	Oz-In/Amp	2.27	3.8	6.12	7.74	11.2
	R <sub>A</sub>	Arm. Resis.	Ohms	0.29	0.40	0.52	0.60	0.80
	K <sub>V</sub>	Back E.M.F	Volts/KRPM	1.7	2.8	4.5	5.7	8.3
	F <sub>C</sub> /K <sub>T</sub>	P <sub>b</sub>	Watts	215	190	206	200	189
<b>B</b>	K <sub>T</sub>	Torq. Sens.	Oz-In/Amp	2.77	4.7	7.48	9.46	13.6
	R <sub>A</sub>	Arm. Resis.	Ohms	0.44	0.61	0.77	0.89	1.18
	K <sub>V</sub>	Back E.M.F	Volts/KRPM	2	3.5	5.5	7.0	10.1
	F <sub>C</sub> /K <sub>T</sub>	P <sub>b</sub>	Watts	176	154	168	164	156
<b>C</b>	K <sub>T</sub>	Torq. Sens.	Oz-In/Amp	3.53	5.9	9.52	12	17.3
	R <sub>A</sub>	Arm. Resis.	Ohms	0.70	0.97	1.25	1.44	1.92
	K <sub>V</sub>	Back E.M.F	Volts/KRPM	2.6	4.4	7.0	8.9	12.8
	F <sub>C</sub> /K <sub>T</sub>	P <sub>b</sub>	Watts	138	122	132	129	122
<b>D</b>	K <sub>T</sub>	Torq. Sens.	Oz-In/Amp	4.41	7.4	11.9	15	21.7
	R <sub>A</sub>	Arm. Resis.	Ohms	1.13	1.52	1.96	2.25	3.01
	K <sub>V</sub>	Back E.M.F	Volts/KRPM	3.3	5.5	8.8	11.1	16.0
	F <sub>C</sub> /K <sub>T</sub>	P <sub>b</sub>	Watts	111	98	106	103	98
<b>E</b>	K <sub>T</sub>	Torq. Sens.	Oz-In/Amp	5.54	9.3	15	19	27
	R <sub>A</sub>	Arm. Resis.	Ohms	1.77	2.40	3.11	3.61	4.67
	K <sub>V</sub>	Back E.M.F	Volts/KRPM	4.1	6.9	11.1	14.0	20.0
	F <sub>C</sub> /K <sub>T</sub>	P <sub>b</sub>	Watts	88	78	84	81	78
<b>F</b>	K <sub>T</sub>	Torq. Sens.	Oz-In/Amp	6.93	11.7	18.7	23.6	34
	R <sub>A</sub>	Arm. Resis.	Ohms	2.78	3.80	4.84	5.57	7.40
	K <sub>V</sub>	Back E.M.F	Volts/RPM	5.1	8.6	13.8	17.4	25.1
	F <sub>C</sub> /K <sub>T</sub>	P <sub>b</sub>	Watts	70	62	67	66	62
<b>G</b>	K <sub>T</sub>	Torq. Sens.	Oz-In/Amp	8.57	14.4	23	29	42
	R <sub>A</sub>	Arm. Resis.	Ohms	4.31	5.76	7.32	8.41	11.29
	K <sub>V</sub>	Back E.M.F	Volts/KRPM	6.3	10.6	17.0	21.4	31.0
	F <sub>C</sub> /K <sub>T</sub>	P <sub>b</sub>	Watts	57	50	55	53	50
<b>H</b>	K <sub>T</sub>	Torq. Sens.	Oz-In/Amp	10.71	18	29	36	52
	R <sub>A</sub>	Arm. Resis.	Ohms	6.84	9.00	11.64	12.96	17.31
	K <sub>V</sub>	Back E.M.F	Volts/KRPM	7.9	13.3	21.4	26.6	38.4
	F <sub>C</sub> /K <sub>T</sub>	P <sub>b</sub>	Watts	46	40	43	43	41

Sold & Serviced By:

 **ELECTROMATE**

Toll Free Phone (877) SERV098

Toll Free Fax (877) SERV099

[www.electromate.com](http://www.electromate.com)

[sales@electromate.com](mailto:sales@electromate.com)

Note: Continuous torque specifications obtained with motor mounted to an 10" x 10" x 0.25" alum. plate at 25 °C ambient. Typical values are within ±10% of rating.

For custom designs please consult factory.

All specifications subject to change without notice.

# MECHANICAL SPECIFICATIONS\*

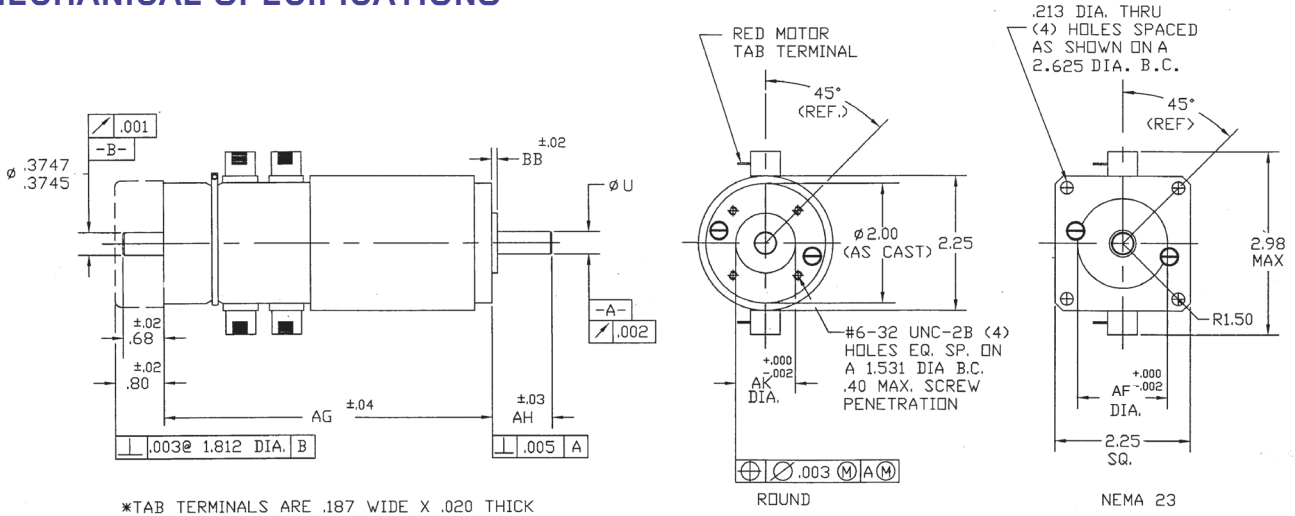

# DIMENSION CHART\*

MOTOR	AG	AG	U DIA.		AH		AK	AF	BB	
	Motor Only Inches (Metric)	Motor Tach Inches (Metric)	STD	NEMA	STD	NEMA	STD	NEMA	STD	NEMA
2105	3.13 (79.5)	4.60 (116.8)	.3750/.3745	.2500/.2495	1.00	0.77	1.000	1.500	0.10	0.06
2110	3.63 (92.2)	5.10 (129.5)	.3750/.3745	.2500/.2495	1.00	0.77	1.000	1.500	0.10	0.06
2115	4.13 (104.9)	5.60 (142.2)	.3750/.3745	.2500/.2495	1.00	0.77	1.000	1.500	0.10	0.06
2120	4.63 (117.6)	6.10 (154.9)	.3750/.3745	.2500/.2495	1.00	0.77	1.000	1.500	0.10	0.06
2130	5.63 (143.0)	7.10 (180.3)	.3750/.3745	.2500/.2495	1.00	0.77	1.000	1.500	0.10	0.06

### METRIC (mm): DIMENSIONS ALL FRAME SIZES

SHAFT: DIA	8j6	MOUNTING: PILOT	25.0
LENGTH	25.0	HOLE SIZE	M4

\*All specifications are for reference only. Please consult the factory for certified dimension drawings. Standard Direction of Rotation: CCW rotation viewed from shaft end with red motor terminal positive with respect to black motor terminal.

### TORQUE PERFORMANCE CURVES

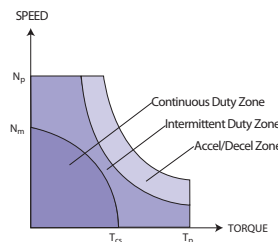

NOTE: Continuous torque specifications obtained with motor mounted to an 10"x10"x.25" aluminum plate at 25 C° ambient. Typical values are within  $\pm 10\%$  of rating.

### STANDARD WINDING SPEED/TORQUE CURVE DATA FOR SIZING A SERVO MOTOR

- $N_m$  = Maximum speed, continuous operation
- $N_p$  = Peak speed, acceleration/deceleration and intermittent duty
- $T_{cs}$  = Continuous stall torque
- $T_p$  = Peak torque

All specifications subject to change without notice.

# TORQUE PERFORMANCE CURVES

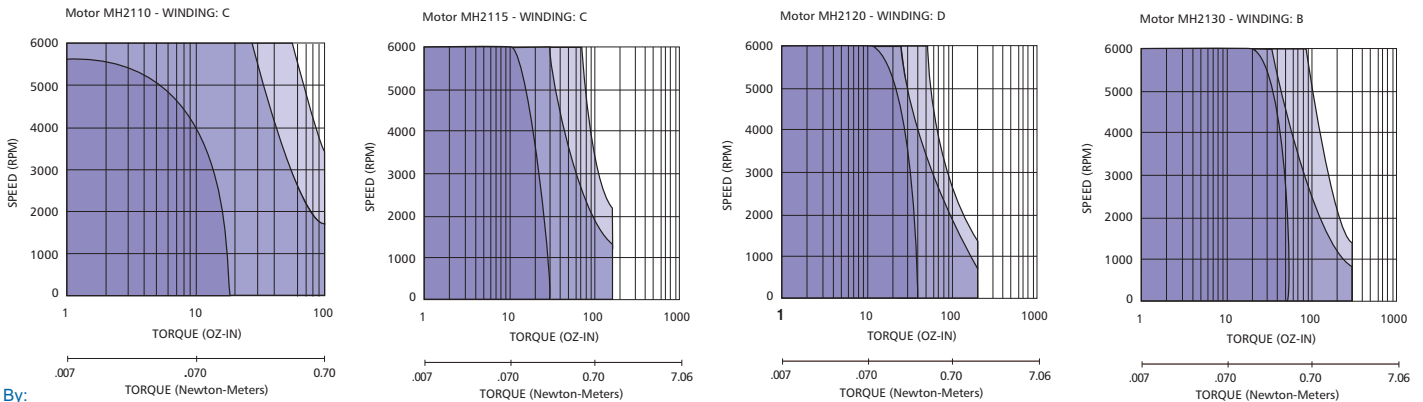

Sold & Serviced By:



Torque speed curves of other windings available, consult factory.

Toll Free Phone (877) SERV098

Toll Free Fax (877) SERV099

www.electromate.com

sales@electromate.com

